

BLU  **NAV**
BE-HYBRID

Electric & connected
add-on motors for boats



Summary

Our vision	p 4
Our mission	p 6
Our technology	p 8
New biomimetic design	p 10
Smart navigation	p 12
Hybrid journey	p 14
<i>BlueSpin Outboard</i>	p 16
<i>BlueSpin Inhull</i>	p 18
<i>BlueSpin Stationary</i>	p 20
Included accessories	p 22
Electric journey	p 24
Engineering office	p 26
Contact	p 28

Our vision

Just as whales gracefully navigate the oceans, our vision is to channel our energy and passion towards developing solutions that will sail us towards a better world, preserving the ecosystems and peace in the vast expanse of the seas.



Forging the Future of Mobility

As the energy transition accelerates in the automotive world, the commitment to sustainability in the marine industry is just setting sail.

Recognizing the impossible batteries challenge for immediate widespread adoption of electric mobility, **BlueNav has focused on addressing current mobility challenges by developing alternative solutions with hybrid propulsion.** Designed for boaters and professional vessels, BlueNav motors allow any type of boat to be converted into a hybrid electric vessel, **today.**

Our engineers have risen to the challenge of embracing the energy transition by envisioning **a comprehensive ecosystem centered around clean energy and propulsion.** This innovative mobility in the boating world combines performance, comfort, and environmental responsibility.



We bring **a concrete response to the energy transition challenges** in the boating industry by offering an alternative solution through hybridization.

Hervé FROUIN
CEO



Our mission

Our essential purpose is to passionately support sustainable navigation, empowering individuals to experience pure bliss and forge an intimate connection with nature. It is our deep-rooted commitment that legitimizes our mission and feeds our unwavering dedication to your satisfaction.

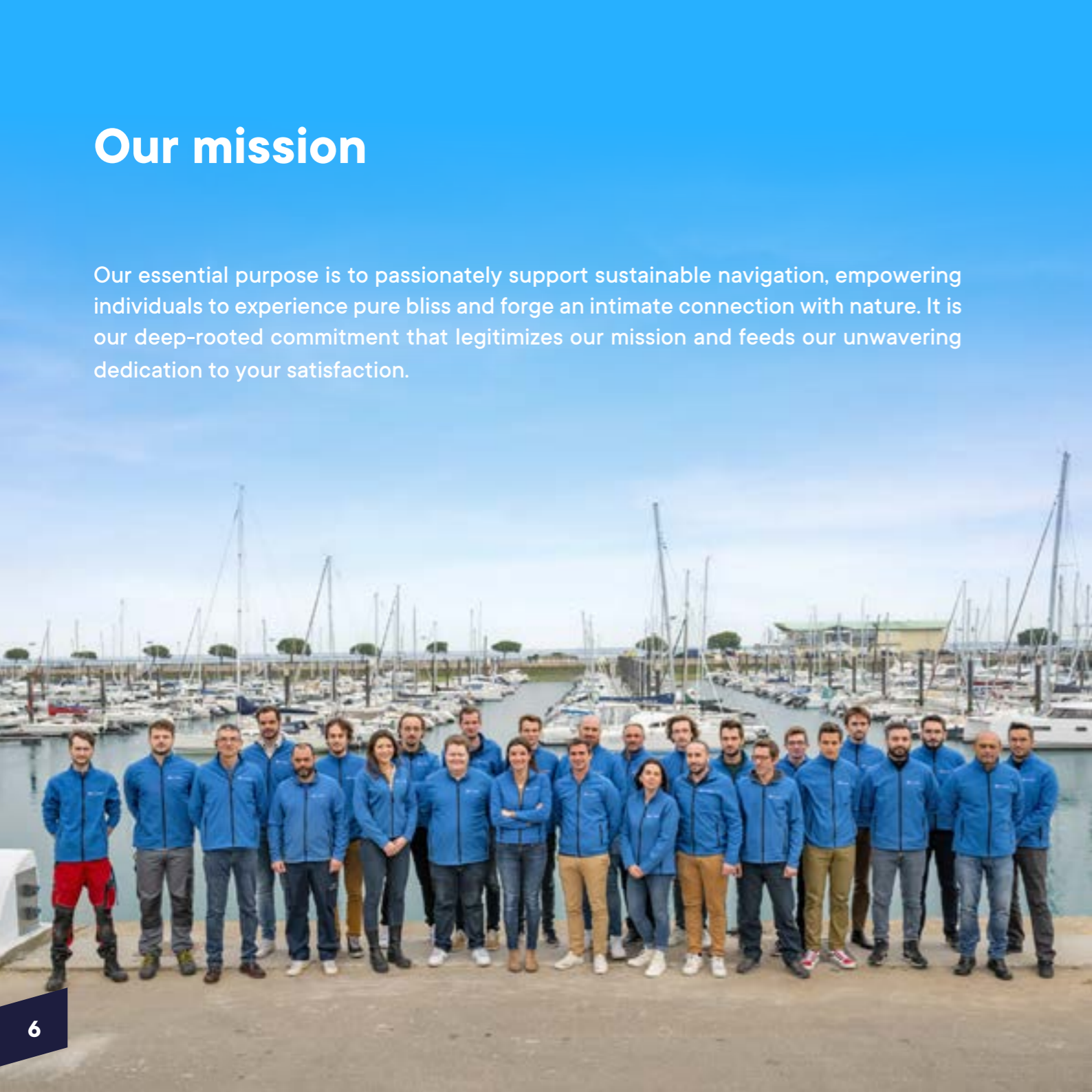

Your Passion mirrored in our Mission

BlueNav offers an unparalleled navigation experience combining sensory pleasure with the modernity of connected propulsion. Navigating has never been so intuitive and user-friendly.

As an expert in onboard marine technologies, **BlueNav found its inspiration at the core of navigators' concerns**, giving rise to this ambitious project: tackling the challenge of sustainable mobility at sea.



We understand that **the experience of navigation is not only about the destination but also about the journey itself**. We strive to create an immersive voyage that goes beyond mere transportation.

Our passion drives us to **provide sailors with means that align with their values and aspirations**. With their satisfaction as our guiding principle, we are dedicated to ensuring that every navigation moment is filled with serenity.

Mathilde GOMBEAUD
Managing director



BLU NAV



Our cutting-edge technology

In pursuit of excellence, BlueNav drew inspiration from the best practices in the industry. Specifically, it found inspiration from the underwater industry, which values both performance and discretion. BlueNav has developed cutting-edge hubless drive propulsion systems tailored for the yachting sector.

0 noise
vibration
emissions

Hubless Drive: a Revolution in Propulsion

A hubless drive motor is a ring-shaped motor that transmits its motion to the propeller through magnetic means. This method of magnetic motion transmission offers numerous advantages:

Increased efficiency

The magnetic transmission of motion minimizes mechanical friction, resulting in improved energy efficiency and reduced power losses.

Reduced maintenance

With fewer mechanical components subject to wear and tear, the ring motor requires less maintenance and has a longer lifespan compared to traditional propulsion systems.

Silent operation

The absence of physical contact between components reduces noise and vibration, providing a quieter and more comfortable boating experience.

Compact design

The annular shape allows for a compact and space-efficient design, maximizing the available space on the vessel.

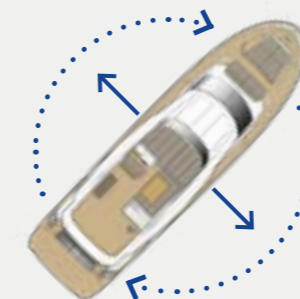
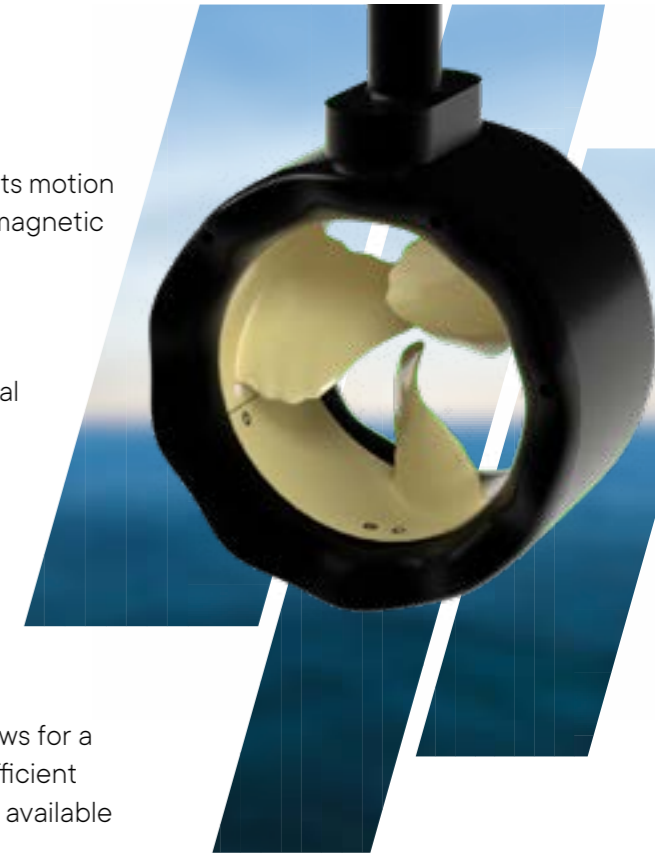

360° thrusting

The responsiveness of the docking system developed by BlueNav enables smoother and more precise maneuvering of the boat, enhancing overall handling and navigation.

New Whale Design

BlueNav's Whale Design embodies the sophistication of nature's influence. Inspired by the graceful dynamics of whales, our hydrodynamics engineers created a harmonious blend of biomimicry and sustainable innovation.

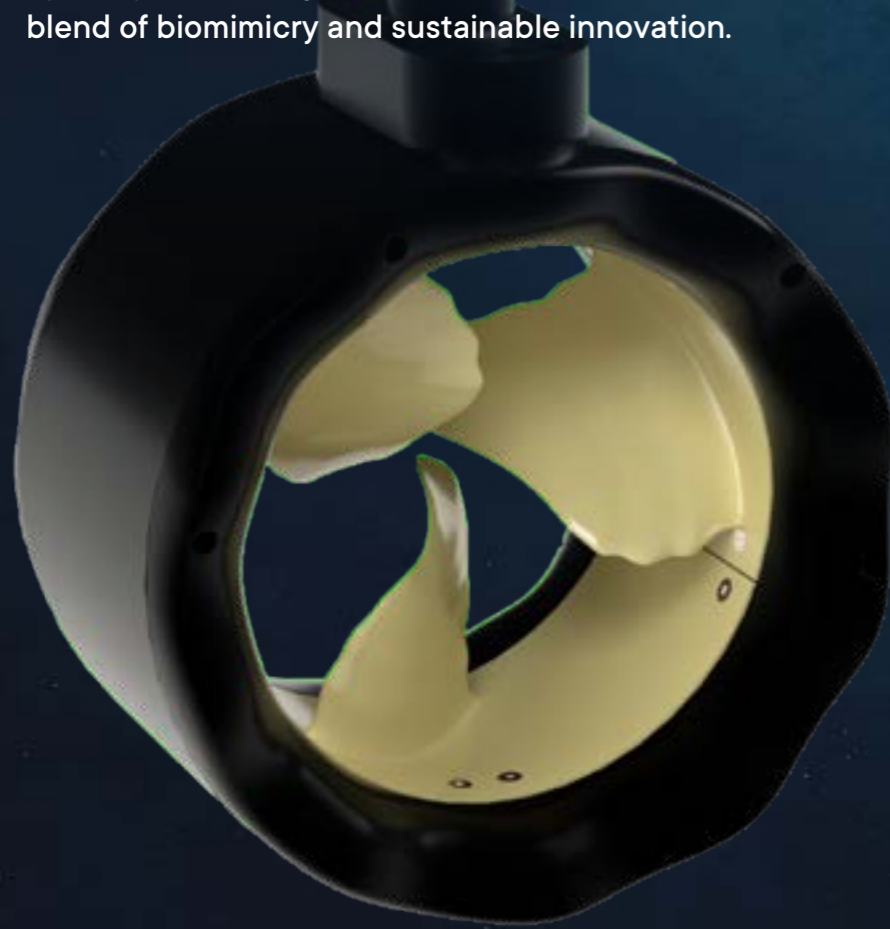

Whale Design, enhanced performances

Biomimetics is always a source of inspiration for humans. While nature follows an incremental and random bias for its evolution, humans can mimic designs that have been shown to be more efficient and quieter, even if, sometimes, they defy traditional engineering theories.

Our engineers demonstrated by CFD (Computational Fluid Dynamics) that the bumps on the flippers of cetaceans and the striations on their belly have a result, they reduce drag, and increase fluid flow efficiency.

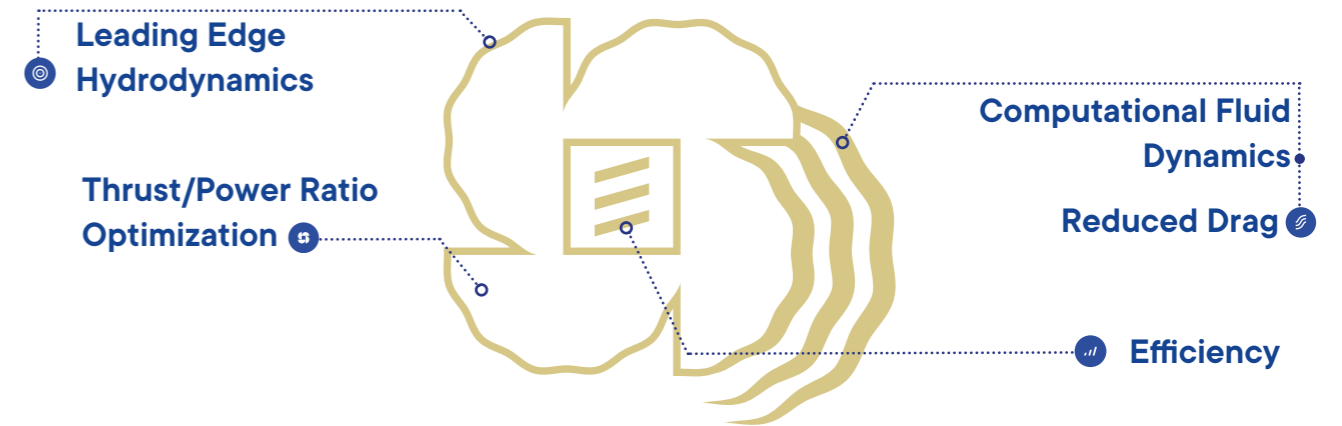

Available with 3, 4, 5 blades for complementary integrations

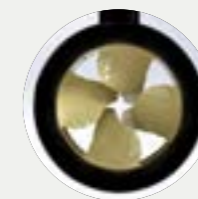
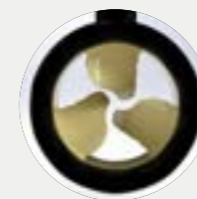

Smart navigation

Navigation is about adapting to surrounding elements –the wind, current, and drift– all of which are energy-consuming factors. By choosing to navigate with BlueNav, the user benefits from an integrated solution and a wealth of connected services.

Integrated HMI solution

The **Human-Machine Interface (HMI)** analyzes real-time data such as current, position, and speed, offering the pilot insights on energy consumption and tips for performance optimization.



New smart navigation features

As automation becomes part of the boating experience, BlueNav's HMI now comes equipped with Autopilot and Cruise Control.

Your boat will maintain its course and speed effortlessly, ensuring a smooth and stress-free navigation journey.

- ✳ **Set Heading** ⚓ **Heading Hold**
- 📍 **No Drift** ⚓ **Self-Steering**

Upcoming navigation services

-  **Autonomous navigation**
This mode makes informed steering decisions based on real-time environmental and underwater topographical analysis.
-  **Virtual anchor (DPS)**
Securely hold your boat in position using GPS with a single click, without damaging the seafloor.
-  **Fishing assistance (DVS)**
Drift fish while keeping a steady course on desired water depths or sea weeds or ground nature.



Electric hybrid range

Enjoy an unparalleled navigation experience combining sensory pleasure with the modernity of connected propulsion.









Together, we are charting a new course towards a brighter future of seafaring.



Hybrid journey

BlueSpin electric add-on motor has been designed to **bridge the gap between the world of traditional combustion engines and electric power**. Now, users can enjoy the best of both worlds, creating a **customized and optimized navigation experience**.

BlueSpin motors effortlessly integrate with diverse types of boats, whether they're newbuilds or undergoing refit. In most cases, installation requires no alteration to the existing propulsion system or the boat's structure, providing **hassle-free transition to electric power** by a professional.

BlueSpin	Outboard	Inhull	Stationary
360° electric propulsion 	✓	✓	✓
Connected interface (HMI) 	✓	✓	✓
Retractable turbine 	✓	✓	✗
Controller 	✓	✓	✓
Charging point 230V 	✓	✓	✓
Newbuild or refit 	✓	✓	✓
No structural modification 	✓	✗	✓
Easy to install 	✓	✓	✓
Low maintenance 	✓	✓	✓







BlueSpin Outboard

BlueSpin Outboard is designed to attach to the transom of a boat and requires no structural modification. Its retractability allows to preserve the original performance of the boat when operating in combustion engine mode.





Outboard

Motorization

-  360° electric propulsion
-  Smart energy control (HMI)
-  Socket charging 230V
-  Retractable turbine
-  Controller
-  Low maintenance

Integration

-  Newbuild or refit
-  No structural modification
-  Easy to install

Power

8 kW 11 hp	Coming soon
15 kW 25 hp	48 V 70 Kg A 895 B 465 C 445 D 565 E 290
30 kW 40 hp	Coming soon

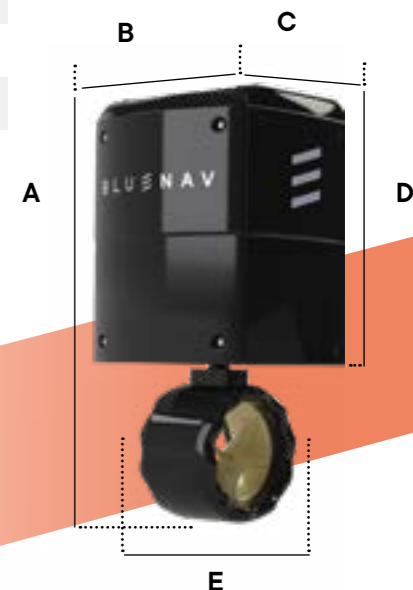
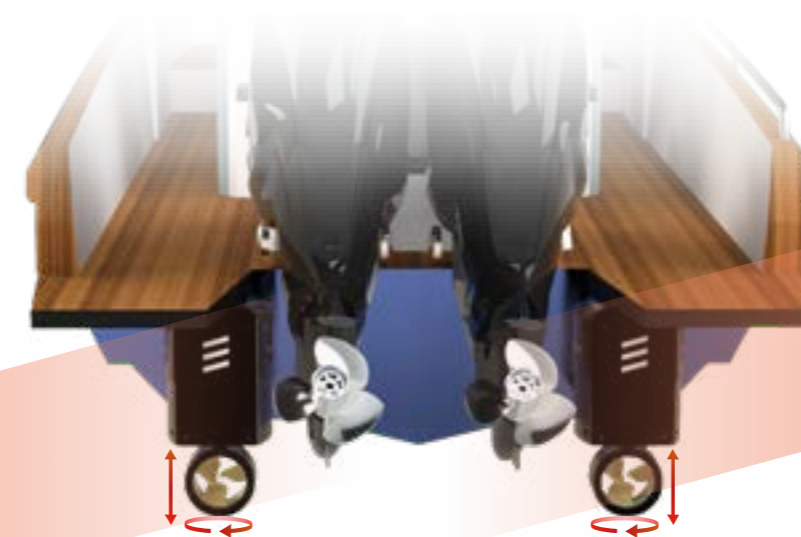







BlueSpin Inhull

BlueSpin Inhull is designed to integrate inside the hull of a boat.



Inhull

Motorization

-  360° electric propulsion
-  Retractable turbine
-  Smart energy control (HMI)
-  Controller
-  Socket charging 230V
-  Low maintenance

Integration

-  Newbuild or refit
-  Easy to install

Power

8 kW 11 hp	Coming soon
15 kW 25 hp	48 V 65 Kg A 995 B 494 C 388 D 575 E 290
30 kW 40 hp	Coming soon

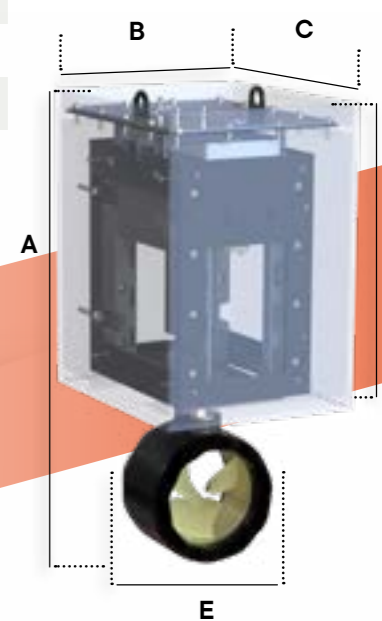
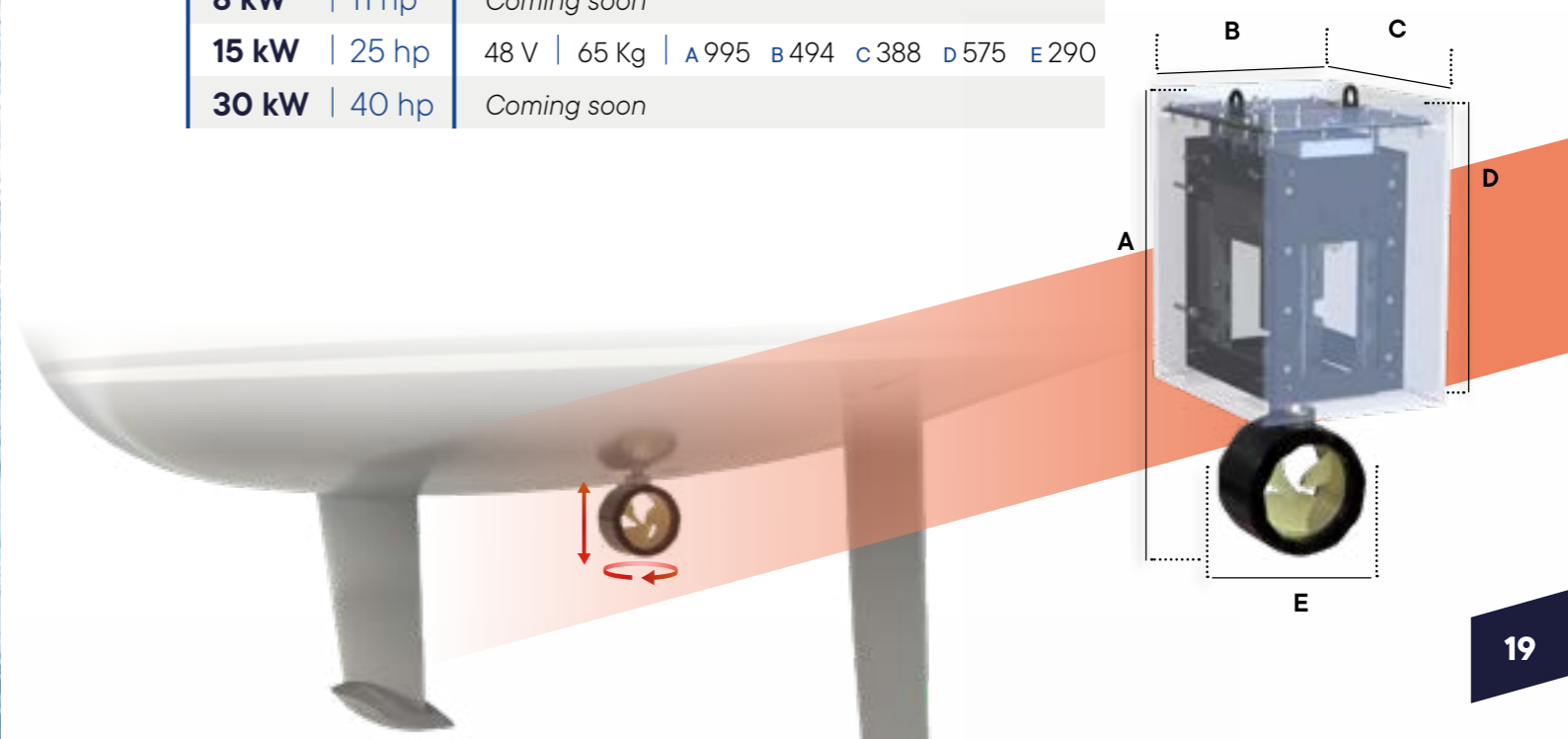





BlueSpin Stationary

BlueSpin Stationary is designed to be mounted under the hull of a boat, and its installation requires no structural modification.





Stationary

Motorization

-  360° electric propulsion
-  Controller
-  Low maintenance
-  Smart energy control (HMI)
-  Socket charging 230V

Integration

-  Newbuild or refit
-  No structural modification
-  Easy to install

Power

8 kW 11 hp	Coming soon
15 kW 25 hp	48 V 45 Kg A650 B290 C720
30 kW 40 hp	Coming soon

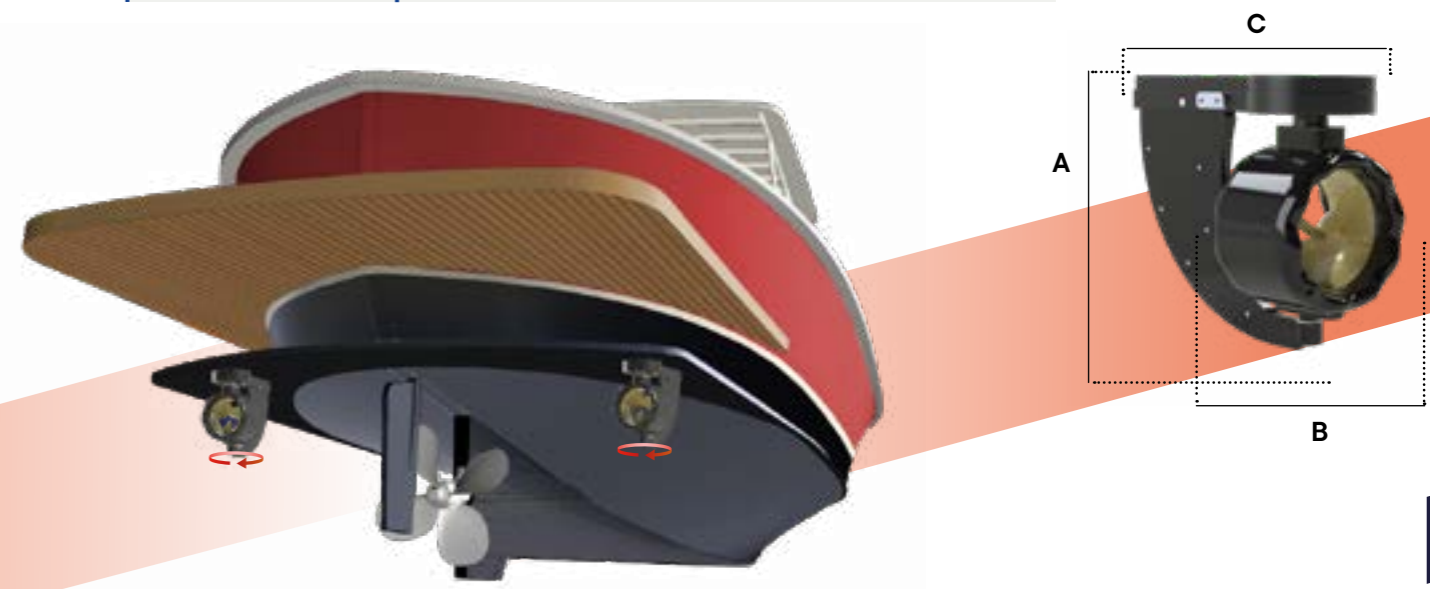

Included Accessories

We also provide or develop additional accessories for BlueSpin in order to ease our motors integration and optimize the customer experience.



1. Ease of use

The E-motor control panel provides 1 joystick for direction, 1-2 throttle levers for propulsion and 4 buttons for on/off - up/down - optional functions - emergency stop.



2. Communication

Our gateway box integrates ethernet to MFD, NMEA 2000, 4G.



3. Connection

Main cables for system connection including fast connectors.



4. Comfort

The turbine fin offers more stability and efficiency during turbine rotation.

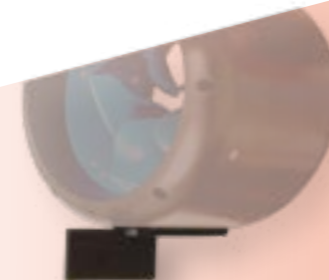

5. Power Conversion

An aluminium cast case including: the turbine controller and its air cooling systems, a PCB and the retraction stepper drivers.



6. Smart Navigation

The BlueNav HMI user interface is compatible with the majority of MFD on the market.



Electric range

In its journey towards emission-free navigation, BlueNav also provides BlueDrive, designed to replace a traditional combustion engine installed on a shaft line.



BlueDrive

Motorization

- ⚡ Electric propulsion
- 🧑‍🔧 Controller
- ✅ Low maintenance
- 📶 Smart energy control (HMI)
- 🔌 Socket charging 230V

Integration

- 🏗️ Newbuild or refit
- ⚙️ No structural modification

Power

17 kW | 27 hp | 48 V | 35 Kg | A 388 B 260 C 260

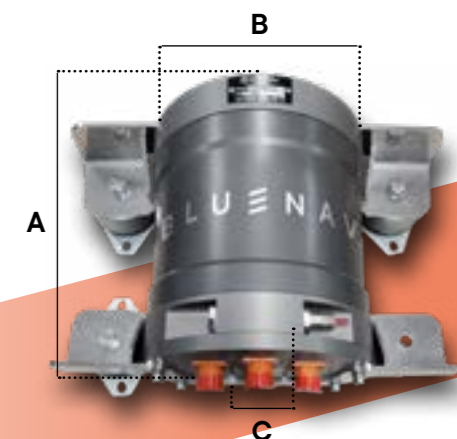
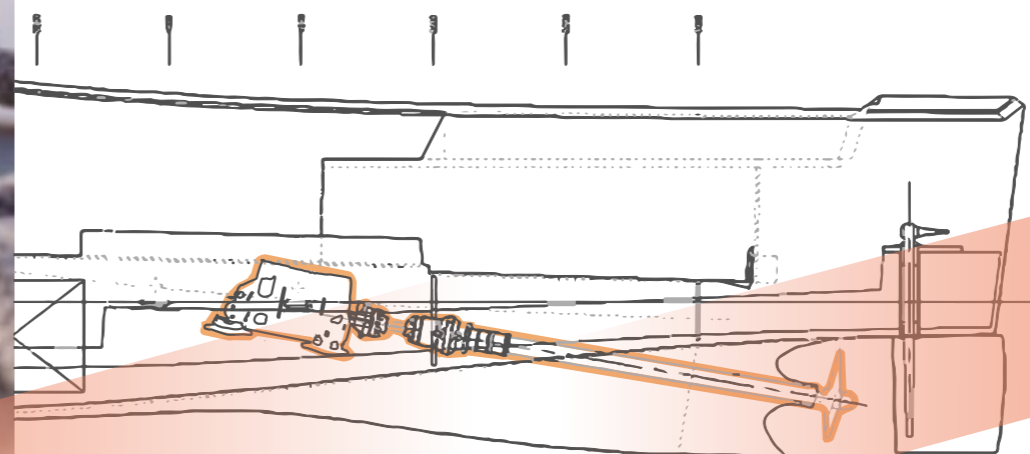

Engineering office



Listening to your projects

The engineers in our design office provide practical solutions for your boat hybridization or electrification projects. As part of a structured quality approach, a dedicated team accompanies and advises you throughout the process:

- Understanding your needs
- Designing the specifications
- Providing assistance with installation and commissioning

Once the solution is operational, our technical support is ready to assist you with maintenance and support.

Ensuring your satisfaction

Your satisfaction is our top priority. Our dedicated team is fully committed to providing you with prompt and efficient support, ensuring your needs are met effectively.

Together, Let's Go Further.

Experience tailored assistance and the comfort of a dedicated contact to support your successful journey.

Beside the available technical documentation, we organize customized training sessions to deepen your product understanding and sharpen your sales and technical skills.



Contact



A global network

BlueNav's expertise shines internationally through an established network of integrators, shipyards, and distributors.

BlueNav is always on the lookout for new partners to expand this distribution network. If you are interested, don't hesitate to contact the sales department.

Contact

Sales department

📍 BLUENAV
17 Quai du Capitaine Allègre
33120 Arcachon, FRANCE

@ sales@bluenav.com

Technical support

📍 BLUENAV
17 Quai du Capitaine Allègre
33120 Arcachon, FRANCE

@ support@bluenav.com

News

Find all the latest BlueNav news on our website or social media channels:



www.bluenav.com



Embrace a slower pace, to sail with purpose. By reducing our speed and hushing the noise of our motors, we intertwine with the world around us. The pleasure we derive is no longer solely about individual power, but a harmonious symphony of interconnected elements.

With BlueSpin, we unlock a sense of freedom and inner serenity that defies description. To navigate is to reconnect with oneself.

Mathilde GOMBEAUD
Managing director





www.bluenav.com

